

Long Shank Collared Eyebolts Whitworth Thread

- Material: High tensile C1045.
- Self-colour finish.
- Electro galvanised finish available on request.
- Heat treated.
- Marked with size, WLL, ID mark & CE.
- Supplied with an EC declaration of conformity.

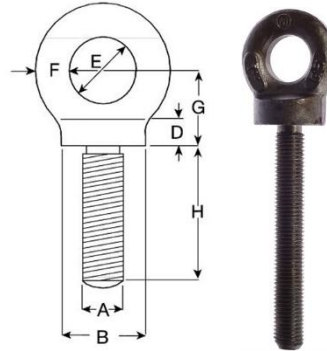

W.L.L tonnes	A (mm)	B (mm)	D (mm)	E (mm)	F (mm)	G (mm)	H(mm)	Weight (kgs/each)
0.25	3/8	2 7/32	9/32	9/16	1 1/32	3/4	7	0.18
0.50	1/2	11/8	3/8	3/4	7/16	1	7	0.25
0.90	5/8	1 13/32	1 5/32	1 5/16	9/16	1 1/4	7	0.44
1.40	3/4	1 11/16	9/16	11/8	2 1/32	1 1/2	7	0.70
2.00	7/8	1 31/32	2 1/32	1 5/16	2 5/32	1 3/4	7	1.05
2.75	1	2 1/4	3/4	1 1/2	7/8	2	7	1.50

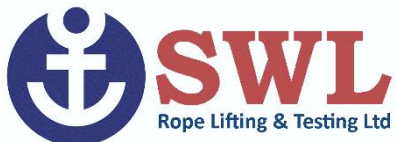

SWL Rope Lifting & Testing, 65-69 Bernard Street, Southampton Hampshire, SO14 3BA

Telephone: 02380 338286

Email: sales@swl.org.uk